

Gas Chromatography: Principles, Advantages and Applications in Food Analysis

Wedad Q. AL-Bukhaiti^{1*}, Anwar Noman^{1,2}, Aseela Saeed Qasim³ and Ammar AL-Farga⁴

¹State key Laboratory of Food Science and Technology & School of Food Science and Technology, Jiangnan University, 1800 Lihu, Avenue, Wuxi 214122, P.R. China.

²Department of Agricultural Engineering, Faculty of Agriculture, University of Sana'a, Sana'a, Yemen.

³Department of Chemistry, Faculty of Education, University of Sana'a, Sana'a, Yemen.

⁴School of Food and Biological Engineering, Jiangsu University, Zhenjiang 212013, PR China.

*Corresponding author email id: wedadqasim@yahoo.com

Abstract – Gas chromatography (GC) is a common kind of chromatography used as a piece of analytical science for segregating and investigating exacerbates that can be vaporized without disintegration. Regular employments of GC are trying the immaculateness of a particular substance, or separating of the distinctive segments of a blend. Development of the analytical methods for identification, purity evaluation and quantification of drugs and food has received a great deal of attention in the field of separation science. This review describes GC method development and validation in general way. A general and very simple approach for the GC method development for the separation of compounds was discussed. Knowledge of the physiochemical properties of the primary compound is of utmost importance prior to the any GC method development. Several steps are being considered for GC method development like column section (stationary phase and dimensions: column id, length, and film thickness), carrier gas selection (Nitrogen, Helium, flow rate), temperature programing (Initial temperature, initial hold, ramp rate, final temperature, and final hold), injector selection, Injector temperature, detector selection and detector temperature. Optimized method is also need to be validated with various parameters (e.g. specificity, precision, accuracy, detection limit, linearity, etc.).

Keywords – Gas Chromatography, Development, Column, Detectors, Application, Validation.

I. INTRODUCTION

Chromatographic separation methods are without any doubt the most frequently employed analytical techniques for compositional analysis [1]. Gas chromatography is a unique and versatile technique. In its initial stages of development it was applied to the analysis of gases and vapors from very volatile components. Gas chromatography is the analytical technique used for product identification (under very controlled conditions) and must be directly coupled to a mass spectrometer when information other than a comparative fingerprint (program) is required, such as positive identification of peaks on the chromatogram [2]. The basic principal of gas chromatography is that greater the affinity of the compound for the stationary phase, more the compound will be retained by the column and longer it will be before it is eluted and detected. Thus the heart of the gas chromatograph is the column in which separation of the component takes place, and to this must be added the source and control of the carrier gas flow through the column, a mean of sample introduction and a means of detection of the components as they elute from the end of the column.

Since temperature will influence the volatility of the analytes, the column is placed in a thermostatically controlled oven [3]. Faster gas chromatographic separation is a generally beneficial option. Since the decrease time of analysis results in the increased sample. Reduction of analysis time can be achieved by changing column parameters: shorter length, smaller column inner diameter, thinner film of stationary phase, or operational parameters: faster temperature program rate, isothermal analysis. Different carrier gas, higher carrier gas flow rate or a combination of both approaches can be applied [4]. Chromatography (GC) 50 years ago, GC has been used to help determine food composition, discover our nutritional needs, improve food quality, and introduce novel foods. Furthermore, GC has been the only adequate approach to measure many of the organic contaminants that occur at trace concentrations in complex food and environmental samples. GC has been instrumental in helping humans realize that we must use caution with agricultural and industrial chemicals to avoid health and environmental damage.

Gas Chromatography (GC) is a normally utilized analytic technique as a part of numerous research and industrial research facilities for quality control and in addition identification and quantitation of components in a mixture. GC is likewise utilized technique as a part of numerous environmental and forensic labs since it takes into consideration the detection of very little quantities. An expansive variety of tests can be analysed the until the compounds are adequately thermally steady and reasonably volatile [5].

II. PRINCIPLES OF GAS CHROMATOGRAPHY

The basis of the separation is a retardation of the individual components as they are moved through a long column by a carrier gas, usually helium or nitrogen. The column consists of a steel or glass tube filled with an inert packing material such as glass or ceramic beads (see Figure 1). In gas-liquid chromatography (GLC), these are coated with an in volatile liquid, so that the surface area of the liquid in contact with the gas is large. For some applications, the packing may be a solid without any liquid coating; it is then called gas-solid chromatography (GSC), but this is less widely used than GLC.

The sample is injected into the carrier gas stream. As it moves through the column with the carrier gas, the molecules of each substance present in the sample will

distribute between the gas and the liquid. Individual molecules will constantly move between the gas and the liquid in a dynamic equilibrium. While a molecule is in the gas phase it will pass along the column, while it remains dissolved in the liquid it will be stationary. The more volatile a substance, the greater proportion of time its molecules will be moving in the carrier gas, and so the sooner it will emerge from the column. In this way each substance will become separated within the column and emerge separated by time at the end.

The time taken from injection to emergence is known as the retention time (R_t), and is characteristic for each substance under any given set of conditions. It depends on the volatility of the substance, as well as the temperature of the column and its length and diameter. Many substances have an inconveniently long retention time at room temperature, and this is overcome by heating the column in an oven. Having separated the components in the column so that they emerge individually, some method of detecting and measuring them is needed. Two types of detector are commonly used: thermal conductivity and flame ionization. Thermal conductivity detectors (TCDs) rely on changes in

the thermal conductivity of the gas leaving the column. The pure helium carrier gas passes over a hot tungsten-rhenium filament, causing it to cool, since helium has a very high thermal conductivity. When a chemical substance emerges with the carrier gas, cooling will be less, and the temperature of the filament will rise. As with most metals, its electrical resistance increases with temperature and this can be measured and recorded. Flame ionization detection (FID) is more frequently encountered in food applications, since many compounds under investigation are organic (containing carbon), and FID is around a thousand times more sensitive than thermal conductivity detection for organics. The gas emerging from the column is burned with a hydrogen and air mixture. This forms ions, which conduct an electric current which can be amplified and recorded on a chart recorder. Although the number of ions formed in this way is small, perhaps only 0.0001 per cent of the total carbon atoms present in the sample, the proportion produced is always constant. This means that the total signal recorded on the chart recorder is proportional to the amount of the chemical substance present [6].

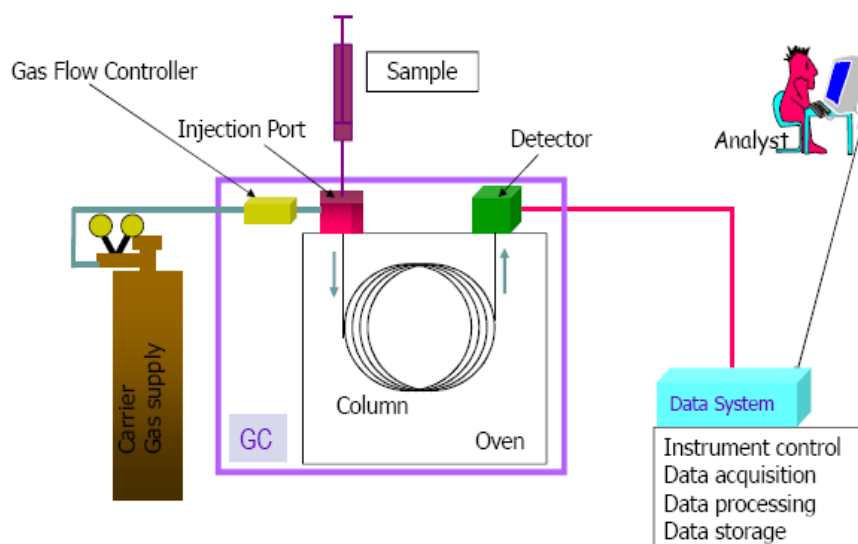

Fig. 1. Schematic Diagram of Gas Chromatography

III. APPLICATIONS

Gas chromatography (GC) is used widely in applications involving food analysis. Typical applications pertain to the quantitative and/or qualitative analysis of food composition, natural products, food additives, flavor and aroma components, a variety of transformation products, and contaminants, such as pesticides, fumigants, environmental pollutants, natural toxins, veterinary drugs, and packaging materials [7]. And particular food applications involving GC, such as carbohydrates and amino acids [8]. Lipids and accompanying lipophilic compounds [9, 10]. flavors and aroma [11, 12].

GC can be used for the direct separation and analysis of gaseous samples, liquid solutions, and volatile solids. If the sample to be analyzed is non-volatile, the techniques of derivatization or pyrolysis GC can be utilized [2]. Gas

chromatography (GC) has been an indispensable analytical technique in the application of fatty acid determinations in oilseed plant breeding, biosynthesis and human metabolism. As well as the characterization of complex mixtures of geometric isomers when combined with other chromatographic separations and spectroscopic identification [13]. Plant breeders uses GC as a more precise and rapid technique for studying the variation and inheritance of fatty acids in oilseed crops such as rapeseed [14]. flaxseed [15], and safflower [16].

IV. ADVANTAGES OF GC PERFORMANCE

Optimum qualitative and quantitative GC analysis of complex mixtures presupposes: (1) good resolution, as shown by sharp and symmetric peaks; (2) high repeatability and reproducibility of retention times; (3) high precision

and accuracy in quantitation based on peak area measurements, i.e. no discrimination of components through volatility, polarity or concentration; (4) minimum thermal and catalytic decomposition of sensitive sample components [17]. The use of fused-silica capillary columns with improved surface inertness, thermal stability and resolution [18]. Best fulfils most of these requirements. In capillary GC the peak resolution, expressed in terms of column efficiency, separation and retention factors [19]. Is primarily affected by the polarity of the stationary phase, column length, internal diameter and film thickness [20, 21, 22]. A variety of columns with different properties are available. In addition, fused-silica columns are highly applicable in practical work due to their flexibility and simplicity in handling and easy connection to GC and mass spectrometers [23]. In order to improve the sensitivity of the GC analyses it is also important to test the effect of carrier gas flow rate, as well as gas flows in the FID, in order to reduce the noise from the hydrogen flame [24]. The carrier gas, usually hydrogen or helium, and its purity can also affect the resolution [20].

V. DEVELOPMENT OF GC METHOD

Methods are developed for new products when no official methods are available. Alternate method for existing (Non-Pharmacopoeial) products are to reduce the cost and time for better precision and ruggedness. When alternate method proposed is intended to replace the existing procedure comparative laboratory data including merit/demerits are made available [25]. Several steps are being considered for GC method development like column selection (stationary phase and dimensions: column id, length, and film thickness), carrier gas selection (Nitrogen, Helium, flow rate), temperature programming (Initial temperature, initial hold, ramp rate, final temperature, and final hold), injector temperature and detector temperature [26].

Steps involved in Method development [27]:

- Understanding the Physicochemical properties of sample.
- Selection of chromatographic conditions.
- Developing the approach of analysis.
- Sample preparation.
- Method optimization.
- Method validation.

VI. SELECTION OF CHROMATOGRAPHIC CONDITIONS

1. Column Selection

A column is of course, the starting and central piece of a chromatograph. An appropriately selected column can produce a good chromatographic separation which provides an accurate and reliable analysis. An improperly used column can often generate confusing, inadequate, and poor separations which can lead to results that are invalid or complex to interpret. There are over 10, 000 compounds that can be analysed by GC and over 400 GC capillary columns [26]. The initial choices of column and supporting instrumentation have a profound influence on the possibilities for, and ultimate results of, separation

optimization. Manipulation of column parameters (stationary phase, inner diameter, length, and film thickness) gives chromatographers control over column efficiency, resolution and speed of analysis. [2]. In gas chromatography, the elution order of analytes is governed by several factors such as latent vapour pressures, solubilities in stationary phase, and propensities for molecular interaction in the stationary phase. All of these effects change with temperature and their concerted effect ultimately determine the equilibrium distribution of solute molecules between the mobile and stationary phase [28]. Selection of Column:

A column is of course, the starting and central piece of a chromatograph. An appropriately selected column can produce a good chromatographic separation which provides an accurate and reliable analysis. An improperly used column can often generate confusion, inadequate, and poor separations which can lead to results that are invalid or complex to interpret. There are over 10, 000 compounds that can be analysed by GC and over 400 GC capillary columns. It is a challenge for a column manufacturer to give detailed column selection guidelines to meet such a wide variety of applications. An optimized chromatographic separation begins with the column. The selection of the proper capillary column for any application should be based on four significant factors which are: stationary phase, column internal diameter, film thickness, and column length. The differences in the chemical and physical properties of injected organic compounds and their interactions with stationary phase are the basis of separation process. When strength of the analyte-phase interactions differs significantly for two compounds, one is retained longer than the other. How long they are retained in the column (retention time) is a measure of these analyte-phase interactions. Changing the chemical features of the stationary phase alters its physical properties. Two compounds that co-elute (do not separate) on a particular stationary phase might separate on another phase of different chemistry [26].

1-1 Selection of Column Internal Diameter (i.d.) High Efficiency

Column id plays two contradicting roles in separation. The efficiency of a capillary column, measured in plates (n) or plates per meter (n/m), increases as the i.d. of the column decreases. This is one of the basic principles behind fast GC but decreased sample loading capacities. When a column is overloaded with sample, the plate number is decreased greatly. If the sample to be analysed contains many analytes, or has analytes that elute closely together, the most narrow i.d. capillary column that is practical should be selected. Note that very narrow bore columns, such as 0.10 or 0.18 mm i.d., may require specialized equipment, such as GC with a pressure regulator that allows higher column head pressure [29].

1-2 Sample Injection Port

For optimum column potency, the sample mustn't be large, and may be introduced onto the column as a "plug" of vapor - slow injection of enormous samples causes band broadening and loss of resolution. The foremost common injection methodology is wherever a micro syringe is

employed to inject sample through a rubber septum into a flash vaporizer port at the top of the column. The temperature of the sample port is sometimes concerning 50°C beyond the boiling purpose of the smallest amount volatile element of the sample [30-32].

1-3 Column Temperature

For precise work, column temperature should be controlled to at intervals tenths of a degree. The optimum column temperature is dependent upon the boiling purpose of the sample. As a rule of thumb [33], a temperature slightly on top of the typical boiling purpose of the sample ends up in associate extraction time of two - half-hour. Least temperatures offer sensible resolution, however increase extraction times [34].

2. Selection of Carrier Gas:

Finding the Best Carrier Gas Average Linear Velocity

Determining the best average linear velocity is fairly easy and only involves a small amount of trial and error. Hydrogen provides the best resolution in shortest amount of time. Helium provides similar resolution, but at a longer analysis time. Nitrogen is not recommended for use with capillary columns due to the extremely long analysis times. When using helium as the carrier gas, try an initial average linear velocity of 30 cm/sec. If better resolution is desired, reduce the velocity to not less than 25 cm/sec; however, the analysis time will be increased. If a shorter analysis time is desired, increase the velocity to 35-40 cm/sec; be aware of potential resolution losses at these higher linear velocities. Average linear velocities of 30-35 cm/sec are used for many analyses when using helium as a carrier gas. When using hydrogen as the carrier gas, try an initial average linear velocity of 60 cm/sec. If better resolution is desired, reduce the velocity to not less than 50 cm/sec; however, the analysis time will be increased. If a shorter analysis time is desired, increase the velocity to 70-80 cm/sec; be aware of potential resolution losses at these higher linear velocities. Average linear velocities of 60-70 cm/sec are used for many analyses when using hydrogen as carrier gas. [35]. The choice of gas to be used as mobile phase in gas chromatography is influenced by the following requirements and considerations:

Inertness, Dryness, Freedom from oxygen, Safety, Cost and Availability [3].

3. Optimization of Column Oven Temperature Program.

The column resides in an oven, and temperature, which greatly affects the effectiveness of the chromatographic separation, is an extremely important factor used in controlling GC. In many cases, isothermal is not the most effective temperature mode for sample separation; in such cases, a temperature program can be used. Most GC temperature program have initial temperature, a ramp (degree increase per minute) and a final temperature. Using a linear temperature program as a starting point if previous analysis information is not available to use as a guide, the first program development step is to try a simple, linear temperature program. To improve the resolution of earlier eluting peaks, decrease the initial temperature or increase the initial hold time. Decreasing the initial temperature usually results in the largest resolution improvement, but

analysis times are substantially increased. The resolution of peaks eluting in the middle of the chromatogram can be altered by change in ramp rate. If there is excessive peak resolution, the ramp rate can be increased to reduce resolution and the analysis time. If there is insufficient resolution, decrease the ramp rate, but there will be an increase in the analysis time. Better resolution of later eluting peaks often occurs when decreasing the ramp rate. Another option to alter resolution of peaks in the middle of a chromatogram is to use a mid-ramp hold. A mid ramp hold is a several minute isothermal portion somewhere during a temperature ramp. Stop the temperature program shortly after last peak has eluted from the column. If column's isothermal temperature limit is reached and peaks are still eluting, a final hold time is necessary. Only use a final hold time if the temperature limit is reached [26, 35].

4. Optimization of Injector Type, Temperature & Injection Volume

Introduction of the sample into GC system is a critical step in separation. The reproducibility of the amount of sample injected is important to ensure the reproducibility of results. A sample can be injected manually into the system or by using an auto sampler system. A major errors in GC is poor injection technique. The injector temperature for separation. The temperature of injector is used to rapidly vaporize the liquid sample into gaseous phase that can be carried to the column for separation. In capillary and micro packed gas chromatography (GC), there are four primary techniques for vaporizing a sample and transferring it onto the inlet of the analytical column: split, splitless, direct, and on-column injections. Of these, split and splitless injections are the most commonly used techniques. Split Injector was selected for analysis of sample with high concentration levels. In the split injection mode, only a fraction of the vaporized sample is transferred onto the head of the column. The remainder of the vaporized sample is removed from the injection port via the split vent line. Split injections should be used only when sample concentrations are high enough to allow a portion of the sample to be discarded during the injection process, while still maintaining a sufficient concentration of analytes at the detector to produce a signal [35, 36].

5. Selection of Stationary Phase

When selecting a column, first determine the samples characteristics to match the columns stationary phase. Stationary phases are in general divided into 3 categories first non-polar second mid-polar and third Polar. Stationary phases are further categorized by Siloxane (non-polar and mid-polar) and Polyethylene glycol (PEG or polar). G1, G2 and G38 (100% Methyl Polysiloxane) does not undergo hydrogen bonding interactions. The change in the elution order of Hexanol and Phenol with G14, G15, G16, G20, G39 and G47 (Polyethylene glycol) is a combination of dipole and hydrogen bonding interaction [26].

6. Optimization of Detector Type & Detector Temperature

A variety of detector is commercially available to be used with GC, each having its own limitations and advantages. The most commonly used detector in GC is flame ionization detector. Detector temperatures and the relative flow rates

of carrier gas, hydrogen and air into the detector are the key operating parameters [26]. A series of standards is defined for evaluation of detector parameters such as drift, noise, sensitivity, linear range, dynamic range etc. The variation in detector response with flow rate depends on whether the detector is concentration or mass flow dependent. For concentration dependent detectors (e.g., thermal conductivity detector, photo ionisation detector) a decrease in the flow-rate does not affect the peak height, which remains approximately constant. However the peak width, and consequently the peak area, increase. In contrast, for

mass flow detection systems (e.g., flame ionization detection, flame photometric detection, nitrogen phosphorus detection) the response is inversely proportional to the retention time [37].

7. Detectors

There are several detectors which may be employed in gas activity. Totally different detectors can offer differing kinds of property. The response of a mass flow dependent detector is unaffected by make-up gas. As shown in the table (1) [38-43].

Table: 1 Types of detectors which may be employed in gas activity

Detector	Type	Support gases	Selectivity	Detectability	Dynamic range
Flame ionization (FID)	Mass flow	Hydrogen and air	Most organic cpds.	100 pg	10 ⁷
Thermal conductivity (TCD)	Concentration	Reference	Universal	1 ng	10 ⁷
Electron capture (ECD)	Concentration	Make-up	Halides, nitrates, nitriles, peroxides, anhydrides, organometallics	50 fg	10 ⁵
Nitrogen- phosphorus	Mass flow	Hydrogen and air	Nitrogen, phosphorus	10 pg	10 ⁶
Flame photometric (FPD)	Mass flow	Hydrogen and air possibly oxygen	Sulphur, phosphorus, tin, boron, arsenic, germanium, selenium, chromium	100 pg	10 ³
Photo- ionization (PID)	Concentration	Make-up	Aliphatics, aromatics, ketones, esters, aldehydes, amines, heterocyclics, organosulphurs, some organometallics	2 pg	10 ⁷

The effluent from the column is mixed with gas and air, and lit. Organic compounds burning within the flame manufacture ions and electrons which might conduct electricity through the flame [44]. An oversized electrical potential is applied at the burner tip, and a collector conductor is found higher than the flame [45]. The present ensuing from the transformation of any organic compounds is measured [46].

VII. CONCLUSION

Gas chromatography is an important analytical technique for qualitative and quantitative analysis in a wide range of application areas. It is fast, provides a high peak capacity, is sensitive and allows combination with a wide range of selective detection methods including mass spectrometry. However, the application area of GC is limited because the molecules to be analysed have to be thermally stable and sufficiently volatile. Numerous molecules do not meet these requirements and hence are not amenable to direct GC analysis. Recent research has resulted in better chromatographic columns and methods for sample preparation that enable a significant expansion of the molecular application range of GC. The strategies exploited include conversion of (macro) molecules into smaller species and approaches to reduce the polarity of molecules.

Abbreviations

mm millimeter
 fg femtogram
 ng nanogram
 pg pictogram

REFERENCES

- [1] Kaal, Erwin, and Hans-Gerd Janssen. "Extending the molecular application range of gas chromatography." *Journal of Chromatography A* 1184. 1 2008, pp. 43-60.
- [2] Grob, Robert L., and Eugene F. Barry, eds. *Modern practice of gas chromatography*. John Wiley & Sons, 2004.
- [3] I.A. Fowles. *Gas Chromatography-Analytical chemistry by open learning*, 2nd Ed., John Wiley & Sons, 1995.
- [4] Mastovska, K., Hajslova, J., Godula, M., Krivankova, J., & Kocourek, V. Fast temperature programming in routine analysis of multiple pesticide residues in food matrices. *Journal of Chromatography A*, 907(1), 2001, pp. 235-245.
- [5] Pravallika. S. Gas Chromatography a Mini Review. *Research and Reviews Journal of Pharmaceutical Analysis*: 5(2), 2016, pp. 55 – 62.
- [6] Holley, Kathy, Mark Pennington, and Paul Phillips. "Gas chromatography in food analysis: an introduction." *Nutrition & Food Science* 95.5 1995, pp. 10-12.
- [7] Lehotay, Steven J., and Jana Hajslova. "Application of gas chromatography in food analysis." *TRAC Trends in Analytical Chemistry* 21.9 2002, pp. 686-697.
- [8] Molnár-Perl, I. "Role of chromatography in the analysis of sugars, carboxylic acids and amino acids in food." *Journal of Chromatography A* 891.1 2000, pp. 1-32.
- [9] Marriott, Philip J., Robert Shellie, and Charles Cornwell. "Gas chromatographic technologies for the analysis of essential oils." *Journal of Chromatography A* 936.1, 2001, pp. 1-22.
- [10] Lercker, G., and M. T. Rodriguez-Estrada. "Chromatographic analysis of unsaponifiable compounds of olive oils and fat-containing foods." *Journal of Chromatography A* 881.1, 2000, pp. 105-129.
- [11] Wilkes, Jon G., et al. "Sample preparation for the analysis of flavors and off-flavors in foods." *Journal of Chromatography A* 880, (1): 2000, pp. 3-33.
- [12] Pais, Pilar, and Mark G. Knize. "Chromatographic and related techniques for the determination of aromatic heterocyclic amines in foods." *Journal of Chromatography B: Biomedical Sciences and Applications* 747, (1): 2000, pp. 139-169.

